



3000 Lakeside Drive, Suite 105N  
Bannockburn, IL 60015-1249

# IPC-TM-650 TEST METHODS MANUAL

**1 Scope** This method is to be used as a guideline for preparing a metallographic specimen of printed boards. The finished microsection is used for evaluating the quality of the laminate system and plated structures (plated-through holes, solder joints, vias, etc.). The plated structures can be evaluated for characteristics of the copper foils, plating, and/or coatings to determine compliance with applicable performance specification requirements.

Metallographic sample preparation is regarded by many as essentially a highly developed skill; this method describes those techniques that have been found to be generally acceptable. It does not attempt to be so specific as to not allow acceptable variations that can differentiate metallographers. Furthermore, the success of these techniques remains highly dependent upon the skill of the individual metallographer.

**Note:** These microsection techniques are processes and are intended as guidelines and thus variations are allowed.

**Note:** The use of the materials listed in Section 4 may be limited or forbidden in some environments. Please review the Safety Data Sheet (SDS) for the materials being used.

**1.1 Method A (Manual) Description** Manual metallographic preparation of sample(s).

**1.2 Method B (Semi or Automatic) Description** Semi or automatic metallographic preparation utilizing dedicated microsection equipment to prepare multiple samples.

## 2 Applicable Documents

**IPC-MS-810** Guidelines for High Volume Microsectioning

**ASTM E 3** Standard Methods of Preparation of Metallographic Specimens

**3 Test Specimens** A test coupon or printed board to be inspected per the applicable performance specification, which includes the features to be evaluated (i.e., plated holes or laminate). This may require multiple microsections.

## 4 Apparatus or Material

**4.1** Sample removal method (see IPC-MS-810 for the best method to meet your needs).

Number <b>2.1.1</b>	
Subject <b>Microsectioning, Manual and Semi or Automatic Method</b>	
Date <b>6/15</b>	Revision <b>F</b>
Originating Task Group <b>Microsection Subcommittee (7-12)</b>	

**4.2** Personal Protective Equipment (e.g., eye protection, gloves)

**4.3** Ventilation system (Fume Hood) in compliance with material SDS (as required)

**4.4** Mount molds.

**4.5** Smooth, flat mounting surface.

**4.6** Release agent (optional).

**4.7** Sample supports (optional for Method A).

**4.8** Sample alignment tools (Method B).

**4.9** Metallographic wet grinding/polishing system or equipment (as applicable).

**4.10** Low magnification visual aid (reticle optional)

**4.11** Metallographic microscope capable of minimum construction integrity magnifications as specified in procurement documentation.

**4.12** Vacuum pump and desiccator or pressure pot (optional).

**4.13** Potting material (maximum cure temperature 93 °C [200 °F]). (For discussion on selection of potting material refer to IPC-MS-810.)

**4.14** Sandpaper. Federation of European Producers of Abrasives (FEPA)(ISO 6344) paper backed Silicon Carbide P (coated) abrasive medium P80-P4000 (United States CAMI (Coated Abrasive Manufacturers Institute) grit range: 80-1200.

**4.15** Polishing Cloths. A hard, low, or no nap cloth for rough and intermediate polishing, and a soft, woven, or medium nap cloth for final polishing.

**4.16** Oxide or colloidal silica polishing suspension (final polish, 0.3 - 0.04 µm [11.8 - 1.57 µin]). (Optional).

IPC-TM-650		
Number <b>2.1.1</b>	Subject <b>Microsectioning, Manual and Semi or Automatic Method</b>	Date <b>6/15</b>
Revision <b>F</b>		

**4.17** Diamond polishing abrasive (6.0 - 1.0  $\mu\text{m}$  [236 - 39.4  $\mu\text{in}$ ]).

**4.18** Polishing lubricant.

**4.19** Specimen etching solution (see 5.5.2.1).

**4.20** Cotton balls and swabs for cleaning and etchant application.

**4.21** Isopropyl alcohol, 25% methanol aqueous solution, or other suitable solvent (check for reaction with the encapsulation media and marking system).

**4.22** Permanent identification marking method (e.g., laser scribing, permanent marker, embedded label, etc.) to provide traceability.

**4.23** Ultrasonic cleaner (optional).

**5 Procedure** The procedure steps of this section are applicable to both Method A and Method B unless otherwise indicated.

**5.1 Removal of Specimen** Remove the required specimen(s) from the product to be tested. Allow sufficient clearance to prevent damage to the area to be examined. Some commonly used methods include sawing using a jewelers saw, miniature band saw, diamond saw or abrasive cut-off wheel; routing using a small milling machine; or punching using a sharp, hollow die (not recommended for thick or brittle materials, i.e., polyimide and some modified epoxy resin systems) (see IPC-MS-810). All samples must maintain required traceability.

## 5.2 Preparation of Specimen

**Note:** Complete any required preconditioning and/or stress testing prior to mounting.

**Note:** To determine correct plane of grind for plated structures with a length of 0.010 inch or less, the diameter of the structure **shall** be required for the assessment. For microvias the diameter of the structure at the capture land layer **shall** be provided. For stacked structures where both structures do not meet center of hole tolerance at the same time, refer to the performance specification for guidance or AABUS.

**5.2.1 Method A** Deburr all edges prior to mounting using rough grind grit in accordance with Table 5-1 to within

approximately 1.27 mm [0.05 in] of final polish depth. Ensure that the evaluation edge is parallel to the mounting surface and the sample maintains perpendicularity as shown in Figure 5-1.

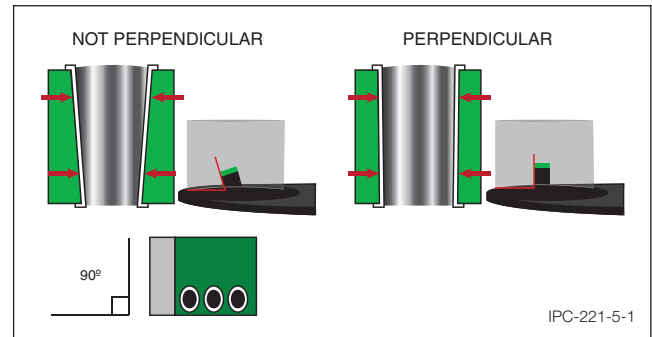

**Figure 5-1 Maintaining Perpendicularity throughout the Microsection Process**

**5.2.2 Method B** Remove the specimen from the printed board or panel such that the tooling pin holes or target PTHs are not damaged.

**5.2.2.1 Inspect Tooling Pin System** Inspect the tooling pin holes or slots to verify they are not plugged or damaged. Clear plugged tooling pin holes with a tool that will not change its dimensional location or enlarge the hole. A drill bit of the same hole diameter is recommended.

Inspect the tooling pins for foreign material adhering to them. Clean the pin surface as required. Discard any pins that are bent or the surface scarred.

## 5.3 Mounting Metallographic Sample

**5.3.1** Clean mount molds and mounting surface and dry thoroughly. Apply release agent (Optional).

**5.3.2** Thoroughly clean the sample using a suitable solvent such as isopropyl or ethyl alcohol. This is especially important when flux or oil is present as it may result in poor adhesion of the potting material causing gaps between the specimen and the material. These gaps make proper metallographic sample preparation extremely difficult, if not impossible.

### 5.3.3 Loading the Specimen

**5.3.3.1 Method A** Stand specimen in mount mold, perpendicular to the base using sample supports, clips, or with the

IPC-TM-650		
Number <b>2.1.1</b>	Subject <b>Microsectioning, Manual and Semi or Automatic Method</b>	Date <b>6/15</b>
Revision <b>F</b>		

use of double-sided adhesive tape. Keep sample in center of mount mold.

**5.3.3.2 Method B** Load specimen on tooling pins. The pins align the target PTHs on a common plane. This common plane assures all the PTHs will grind to the center of the hole at the same instance.

Push the tooling pins into the tooling holes or slots. The pins must fit snugly.

**5.3.4 Preparing Potting Material** Personal protection is recommended to prevent skin sensitization. Prepare potting material to ensure cure temperature does not exceed 93 °C [200 °F]. Mix by folding the potting material in such a way so as to minimize air bubbles.

**5.3.5 Pouring Potting Material** Fill the mount mold carefully with potting material, by pouring from one side to ensure adhesion to all sample surfaces.

**5.3.5.1 Method A** The sample must remain upright while pouring.

**5.3.5.2 Method B** Assure the tooling pins do not shift position or rise up while pouring and/or curing of the potting material.

**5.3.6 Removal of Vacuum or Pressure for Potting Materials** While in a liquid state, potting materials may require vacuum or pressure in order to achieve proper encapsulation. Remove vacuum or pressure prior to cure to prevent undue stress on the specimen.

**5.3.7 Cure and Mount Removal** Allow specimen to cure and cool to room temperature before removing hardened mount from mount mold. The minimum qualities the mount should exhibit are:

- The potting material is hard and not tacky.
- Minimal bubbles in the potting material.
- No gaps between the potting material and the sample.
- All gaps in structure to be evaluated should be filled with potting material.

The presence of these deficiencies will result in sample preparation difficulties, as noted in 5.3.2.

**5.3.8 Marking of Specimen** Identify the specimen by a permanent method (see 4.22). The selected marking system should remain unaffected by subsequent processing.

### 5.3.9 Mount Preparation

**5.3.9.1 Method A** Remove sharp edges and flatten top with low grit (240) sand paper.

**5.3.9.2 Method B** Remove the excess mounting material from the exposed ends of pins.

**5.4 Grinding and Polishing** The following is a description of the basic grinding and polishing steps. Other methods may be required by contract. See Table 5-1 for examples of 2, 3, 4, and 5-step methods for Method A and Table 5-2 and Table 5-3 for Method B.

The minimum qualities the mount **shall** exhibit are:

- 1) The grinding and polishing accuracy of the microsection **shall** be such that the viewing area of each of the PTHs is within 10% of the drilled diameter of the hole as shown in Figure 5-2.
- 2) Only fine grind scratches apparent on the mount when viewed at 100X magnification.
- 3) Little or no gap between the potting material and the specimen(s).
- 4) No residual abrasive paper grit material on the mount surface.
- 5) The ground surface has only one plane of material removal. If the mount has several planes of material removal, portions of the sample will not polish since the odd surface never touches the polishing cloth.

**Note:** Ultrasonic cleaning is highly recommended, especially between the finer grinding steps, prior to rough polishing and between all polishing steps. It is the nature of printed board specimens, especially those with epoxy base material following thermal exposures, to contain voids that can trap grinding and polishing residues that are not removed during simple rinsing. Care needs to be exercised not to damage the specimen surface with excessive ultrasonic cleaning. Specimen sample can be placed with the polished surface perpendicular to the bottom of the vessel. Ultrasonic cleaning for as little as one minute can damage a polished surface.

Number <b>2.1.1</b>	Subject <b>Microsectioning, Manual and Semi or Automatic Method</b>	Date <b>6/15</b>
Revision <b>F</b>		

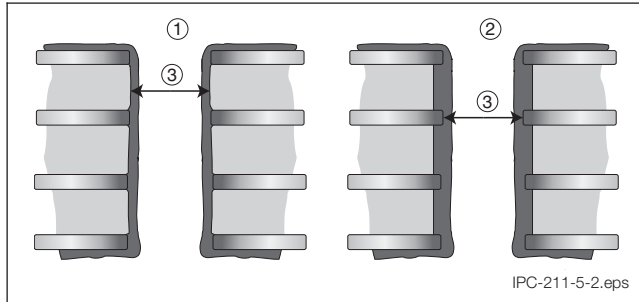

**Figure 5-2 Plated Hole Microsection (Grinding/Polishing) Tolerance**

**Note 1.** Measurement Example with a Negative Etchback Process

**Note 2.** Measurement Example with an Etchback/Desmear Process

**Note 3.** Center of Hole Measurement Location

**Note 4.** Minimum Viewing Area Length = Drill Diameter x 0.9

**Note 5.** Maximum Viewing Area Length = Drill Diameter

#### 5.4.1 Grinding Method A

**5.4.1.1 Rough Grinding** Rough grind the mount prior to the feature intended to be evaluated with abrasive medium.

Wheel speeds of 200 to 300 rpm are generally used during grinding.

Rotate the specimen 90° between each successive grit size and grind for two to three times the time it takes to remove the scratches from the previous step. The scratch removal can be verified by microscopic inspection between steps. It is of great importance that the ground surface of the microsection is in a single plane. The purpose of rotating the microsection 90° between successive grit sizes is to facilitate inspection. If scratches are observed to be perpendicular to those made during the last step performed, it is a good indication that the surface is not flat and the microsection requires additional grinding. If the surface of the microsection is not flat upon completion of the grinding operations, it may not be possible to remove all of the grinding scratches during fine grinding.

**Caution:** Copious water flow must be used to prevent overheating, damage to the specimen, and removal of grinding debris on all grinding steps.

**5.4.1.2 Fine Grinding** The final abrasive medium (ANSI 600 grit/P1200 FEPA) should finish at the axial centerline of the intended feature to be evaluated, such as the plated structure.

#### 5.4.2 Grinding Method B

**5.4.2.1 Tooling Stops** The mount holder has tooling stops to allow the equipment to grind a set distance. These stops must be calibrated for each abrasive paper grit to assure that any scratches from the previous step are removed. See IPC-MS-810 for a detailed discussion and examples.

**5.4.2.2 Grind Pressure** The equipment's pressure setting is the direct force on a load cell. To determine the pressure on each mount, divide the pressure setting by the surface area of the mounts being processed. See IPC-MS-810 for a detailed discussion and examples.

The recommended pressure setting for six mounts at 38.1 mm [1.5 in] diameter is 351.5 g/sq. cm (5.0 psi) with the wheel rotation between 300 - 600 RPM.

**5.4.2.3 Other Variables** Recommended variables to be familiar with are length of time the abrasive paper removes material efficiently, scratch size the abrasive paper causes on the specimen(s) surface, and water quality (undissolved particles that can cause scratches; i.e., calcium deposits).

**5.4.2.4 Grind the Mounts** Be liberal with the amount of water used to promote efficient removal of material by the abrasive paper. The hardness of the specimen will dictate the number of rough and fine grind steps needed to reach near the center of the hole. The rough grind grits ANSI 180-240 (P180 - P240 FEPA) are used to enter the edge of the PTH, and the fine grind grits ANSI 400-600 (P800-P1200 FEPA) are used to grind near the center of the hole. The distance to stop short of the center is determined by the scratch size of the last grind step used.

A recommended grinding process from which to start development is provided in Table 5-2.

**5.4.2.5 Clean the Mounts** Clean the mount surface with a mild hand soap to remove the abrasive grit. This is especially important when the same mount holder is used for grinding and polishing. Be careful not to scratch the surfaces to be evaluated while cleaning.

**5.4.3 Polish** The diamond polish media is preferred for printed boards. Diamond media substantially reduces the risk of metal smear and rounding. Diamonds provide a sharper definition of copper surfaces to evaluate for separation of conductive surfaces.

IPC-TM-650		
Number <b>2.1.1</b>	Subject <b>Microsectioning, Manual and Semi or Automatic Method</b>	Date <b>6/15</b>
Revision <b>F</b>		

**Table 5-1 Suggested Grinding/Polishing Steps – Method A<sup>1,2</sup>**

2 Step <sup>3</sup>	3 Step	4 Step	5 Step	Grit ANSI (FEPA)	
				60 (P60)	Rough Grinding
				80 (P80)	
				120 (P120)	
				180 (P180)	
				220 (P220)	
				240 (P280)	
				280 (P320)	
				320 (P320)	
				400 (P800)	Fine Grinding
				600 (P1200)	
				800 (P2000)	
				1200 (P4000)	Polish
				5 micron	
				3 micron	
				1 micron	
				0.25 Micron	

**Note 1.** The metallographer should recognize the fact that the coarser grit sizes (180, 240, and 320) induce a larger depth of deformed and fragmented material. Since the depth of deformation decreases sharply below a particle size of about 30.0 μm [1181 μin] (400 grit), it is better practice to spend longer times on 400 grit and especially 600 grit to achieve the final plane sectioning, rather than on the coarser grit sizes.

**Note 2.** The multiple step method represent ranges that can be used and any one grit size can be used per step.

**Note 3.** The 2 step process may be used for in-process checks but is not recommended for final acceptance of product.

**Table 5-2 Recommended Grinding Process – Method B**

	Step 1	Step 2	Step 3
Abrasive grit size	P180	P 400(opt)	P1000
RPM	200-300	200-300	200-300
Pressure (g/sq.cm)	351.5	351.5	351.5
Time	15 seconds after the stops touch		

**5.4.3.1 Rough Polish** Rough polish (6 - 3 μm [236 -118 μin]) the specimen using a hard, low, or no nap cloth. Reduced wheel speeds are generally used during final polishing due to the increased drag on the microsection. Utilize recommended lubricant for each polishing medium. Following rough polishing, microscopically examine the specimen to verify removal of all previous grit scratches. Ultrasonically clean the specimen, if desired.

**5.4.3.2 Fine Polish** Continue polishing with 1.0 - 0.25 μm [39.4 - 118 μin] using a hard, low, or no nap cloth and microscopically examine the specimen to verify the removal of all the previous scratches.

**5.4.3.3 Method B – Polish Process Setup** The tooling stops are recessed or removed from the mount holder during

polishing. The reason for this is that the polish process removes a negligible amount of material and will not change the flatness of the surface. The number of polish steps is determined by the hardness of the specimen(s), distance to the center of the hole, and scratch size of the last fine grind step. There may be multiple intermediate polish steps but only one final polish step.

**5.4.3.4 Method B – Intermediate Polish Steps** The intermediate steps must remove the fine grind scratches and prepare the surface for the final polish step. The recommended process settings for six mounts at 38.1 mm [1.5 in] diameter is less than 351.5 g/sq. cm [5.0 PSI], a medium to hard polish cloth, short nap surface, and low wheel RPM (100-200). Additional variables that must be considered are volume of lubricant, lubricant types, abrasive size, abrasive type (diamond or oxide), and process time.

**5.4.3.5 Method B – Final Polish the Mounts** The final polish step removes the scratches from intermediate polishing and prepares the surface for evaluation. The recommended process setting for the same surface areas as 5.4.3.4 are a medium to soft polish cloth, low wheel RPM (100 - 200), and

IPC-TM-650		
Number <b>2.1.1</b>	Subject <b>Microsectioning, Manual and Semi or Automatic Method</b>	Date <b>6/15</b>
Revision <b>F</b>		

low pressure setting 351.5 g/sq. cm [5.0 PSI] or less. Additional variables that must be considered are volume of lubricant, type of nap surface on polish cloth, and process times. The type of abrasive used must be diamond (maximum rated size: 1.0 µm [39.4 µin]) or colloidal silica.

**WARNING:** If a high nap polish cloth is used too long in the final polish, the inspectors ability to see defects can be hampered. This step must be engineered for short process times (30 seconds or less) with a careful balance of lubricant to prevent copper rounding.

A recommended polish process from which to start development is provided in Table 5-3.

**Table 5-3 Recommended Polishing Process - Method B**

	Intermediate	Final	Optional <sup>1</sup>
Type of cloth	Napless	Napless	Nap
Type of polish abrasive	Diamond	Diamond	Diamond
Polish abrasive size	3.0 µm [118 µin]	1.0 µm [39.4 µin]	1.0 µm [39.4 µin]
Time	—	—	30 sec max.
Pressure (g/sq. cm) [PSI]	351.5 [5.0 psi] or less	351.5 [5.0 psi] or less	351.5 [5.0 psi] or less

**Note 1.** When inspecting for innerlayer separations, the optional polish step **shall not** be used (see 6.2).

**Note 2.** Generally, polishing using medium pressure during the above steps is sufficient if the microsection has been ground correctly. This final step is only performed for 10 - 20 seconds using light to medium pressure when using oxide or silica polishing compounds. When using diamond compounds on soft woven cloths, final polishing may extend several minutes (see 6.3).

**5.4.3.6** Rinse in mild soap and warm water or IPA and blow dry.

**Caution:** Do not touch or wipe surface with anything that might cause scratches to the polished surface.

**5.4.3.7** Examine and repolish, beginning with 6.0 µm [236 µin] diamond, if necessary, until:

- 1) There are no scratches larger than those induced by the final polishing abrasive.
- 2) The specimen is not higher or lower than the mounting material (rounding of metal surfaces).
- 3) There is no smearing of the copper plating into the PTH or base material.
- 4) The plane of microsectioning is at the centerline of the hole as defined by the governing specification. If the grinding

depth is insufficient, additional grinding and repolishing may be required.

- 5) There is little, if any, visible preparation induced damage to the glass fibers of the base material.

See IPC-MS-810 for photomicrographs illustrating some of the above qualities.

## 5.5 Examination of Microsections

**5.5.1 “As-Polished” Condition** When specified, examine the microsection of multilayer printed boards in the “as-polished” condition to assess attributes such as internal layer separation (which may appear as dark lines or partial dark lines). These areas should be documented prior to microetching and verified after metallographic etching. There may not be a one-to-one correlation of all separations noted “as-polished” versus those noted after etching, when examined at the specified magnifications.

It is recommended to microetch immediately after the “as-polished” evaluation to avoid oxidation.

### 5.5.2 Microetched Condition

**Caution:** Over etching may totally obscure the demarcation line between the copper foil and electroplated copper, preventing accurate inspection.

**5.5.2.1** Prepare a small volume of copper etch solution such that:

- a) (no more than 10ml) containing 50/50 v/v of ammonium hydroxide (nominally 28%; grade is not defined) and stabilized hydrogen peroxide (nominally 3%; grade is not defined). This is the most active concentration and will last about one hour.

**Note:** Hydrogen peroxide solution is light sensitive and should be stored in an opaque container.

- b) The addition of 25 ml of water (distilled or reverse osmosis) will dilute the solution, resulting in longer etching times, which may be desirable in certain situations. This concentration will have to be remade with each batch.

**5.5.2.2** Expose the surface of the microsection to the etch solution by using one of the following methods:

- a) Swab

- 1) Apply etchant to a swab (outcome based control: no nonconforming scratches caused by swab).

IPC-TM-650		
Number <b>2.1.1</b>	Subject <b>Microsectioning, Manual and Semi or Automatic Method</b>	Date <b>6/15</b>
Revision <b>F</b>		

- 2) Activate the etchant with a copper solid (i.e., plated copper/copper foil). Use a cotton swab to lightly rub a piece of copper and return swab to solution.
- 3) Gently swab the surface of the microsection (outcome based control: grain structure and plating interfaces are slightly exposed).
- 4) Rinse with running tap or deionized water (quality is not defined).
- 5) Rinse in suitable solvent (optional).
- 6) Blot dry with cloth or blow dry (outcome based control: no nonconforming scratches caused by cloth, no oil or debris from gas source).

b) Submersion

- 1) Activate the etchant with a copper solid (Using appropriate method).
- 2) Submerge microsection surface in etchant.
- 3) Provide a means to refresh the etchant at the surface where the reaction is taking place (nominally 3 to 5 seconds, outcome based control: grain structure and plating interfaces are slightly exposed).
- 4) Rinse with running tap or deionized water (quality is not defined).
- 5) Rinse in suitable solvent (optional).
- 6) Blot dry with cloth or blow dry (outcome based control: no nonconforming scratches caused by cloth, no oil or debris from gas source).

## 5.6 Evaluation

**5.6.1** Refer to the appropriate printed board performance specification for magnification and evaluation requirements of completed microsection.

## 6 Notes

**6.1 Overplating** Overplating the specimen per ASTM E 3 with a layer of copper or other plating with a hardness similar to the specimen, prior to encapsulation, provides better edge retention, thereby providing more accurate final finish thickness measurements. Plating can be done electrolytically or with electroless solutions. Thoroughly clean the specimen surface prior to plating to ensure good adhesion of the plating. Milder cleaning treatments that involve detergents, solvents, mild alkaline, or acidic solutions are recommended. Copper and nickel are predominantly used in metallographic laboratories. It is recommended that the plating thickness be at least

5 µm [0.0002 in]. This process is optional and is not for standard evaluation purposes.

**6.2 Plating Separation Evaluation** For a more accurate evaluation of possible internal plating separations (e.g., inner layer interconnect and via to target land separation), the following procedure is recommended to remove the etch demarcation line and return a micro-etched sample to an as-polished condition:

- 1) With the wheel in a stationary position, gently and manually grind the specimen using copious amounts of water and 600 grit abrasive medium. Six to eight double strokes should be sufficient. This action will remove any copper metal smear that may have occurred over the plating separation during rotary polishing.
- 2) Rinse and dry specimen and repolish per 5.4.3.1 and 5.4.3.2, then reexamine to determine if any internal plating separation exists.

## 6.3 Polishing Considerations

- The use of napped cloths can result in poor edge retention (rounding) and relief between constituents since it exacerbates the varying rates of material removal (i.e., tin-lead alloy and the softer encapsulation media are removed at a faster rate than the copper or glass fibers in the base material); the higher the nap, the more the effect. The user needs to minimize the polishing time and use ample lubricant and light pressure during final polishing. When using diamond compounds on soft woven cloths, final polishing may extend several minutes.
- Reduced wheel speeds of 100 to 150 rpm are generally used during final polishing due to increased drag on the microsection.
- Typically, 6.0 µm [236 µin] followed by 1.0 µm [39.4 µin] diamond and a 0.04 µm [1.57 µin] colloidal silica or 0.05 µm [1.97 µin] alumina have been used successfully. However, other variations such as 6.0 µm [236 µin], 3.0 µm [118 µin], and 0.25 µm [9.84 µin] diamond have also been used successfully. Some have even used 1.0 µm and 0.3 µm [39.4 µin and 11.8 µin] alumina on napless cloths followed by 0.05 µm [1.97 µin] alumina on a soft, medium napped cloth.

**NOTE:** Alumina and napped cloths can be used successfully, depending upon the skill of the metallographer, but will generally result in poorer edge retention and more relief effects than the diamond compounds (see Section 7, Reference 1).

IPC-TM-650		
Number <b>2.1.1</b>	Subject <b>Microsectioning, Manual and Semi or Automatic Method</b>	Date <b>6/15</b>
Revision <b>F</b>		

**6.4 Horizontal Microsection** A performance standard may require, for referee inspections (such as smear, breakout, interconnect separations, etc.), a horizontal grind (perpendicular to the original vertical plane) on a vertical microsection. This method has a low success rate when the separation affects less than 50% of the internal layer thickness (as noted on the vertical microsection).

**6.5 Etchants** There are other etchant solutions that have been used or that may be developed for etching copper. Care must be exercised in their selection and use because of the sensitive nature of the electrolytic, electroless, and foil etching characteristics as well as possible galvanic effects in the presence of tin-lead (see Section 7, Reference 2, and IPC-MS-810).

When studying tin-lead solders, it is sometimes helpful to use etchants specifically designed to reveal those alloy's microstructures (see Section 7, Reference 2).

## 7 References

Additional references on metallographic laboratory practice include the following:

- 1) Metallographic Polishing by Mechanical Means, L.E. Samuels, American Society for Metals, 1982, ISBN: 0-87170-135-9.
- 2) Metallographic Etching, Gunter Petzow, American Society for Metals, 1978, ISBN 0-87170-002-9.
- 3) Metallography Principles and Practice, George F. Vander Voort, McGraw-Hill, 1984, ISBN: 0-07-0669780-8.
- 4) Metals Handbook Desk Edition, Edited by Howard E. Boyer and Timothy L. Gall, American Society for Metals, 1985, ISBN: 0-87170-188-X.