



# IPC-TM-650 TEST METHODS MANUAL

Number <b>2.4.9</b>	
Subject <b>Peel Strength, Flexible Printed Wiring Materials</b>	
Date <b>10/88</b>	Revision <b>D</b>
Originating Task Group <b>N/A</b>	

**1.0 Scope** This test method defines the procedure for determining the bond strength of copper foil clad flexible dielectric material.

**2.0 Applicable Documents** None

**3.0 Test Specimens** If a statistically sound evaluation by a given supplier can prove that die cut and etched specimens differ, the preparation giving the lower measurement can be the only preparation tested. In case of conflict, the die cut sample will be used as the referee method. The sample preparation will be the same for as received, after solder and after aging.

### 3.1 Type A—Etched Specimen

**3.1.1** The test specimen shall consist of an etched conductor pattern in accordance with Figure 1. **Note:** Conductors are 3.2 mm wide x 228.6 mm long [0.125 inches wide by 9.0 inches long].

**3.1.2** A minimum of four specimens, two from the machine direction and two from the transverse direction, shall be prepared for each of the procedure Methods A, C, E. If a statistically sound evaluation by a given supplier can prove that MD and TD measurements differ, the direction giving the lower measurement can be the only direction tested. If the two directions are the same, only the MD direction needs to be tested. In the event a test specimen tears during testing, another test specimen will be prepared to replace it.

**3.1.3** For double clad laminate, a separate sample unit shall be prepared and tested for each side.

### 3.2 Type B—Die Cut Specimen

**3.2.1** The test specimen shall consist of a strip of clad flexible material 12.7 mm wide by 228.6 mm long [1/2 inch wide by 9 inches long].

**3.2.2** A minimum of four specimens, two from the machine direction and two from the transverse direction, shall be prepared for each of the procedure Methods B, D, F. If a statistically sound evaluation by a given supplier can prove that MD and ID measurements differ, the direction giving the lower measurement can be the only direction tested. If the two direction are the same, only the MD direction needs to be tested.

**3.2.3** For double clad laminate, a separate sample unit shall be prepared and tested for each side. The copper foil on the nontest side may remain to provide stability to prevent tenting of the specimen from the German Wheel (free wheel rotary drum).

### 4.0 Test Equipment

**4.1 Testing Machine** Power driven testing machine, crosshead autographic type, or an equivalent constant speed drive machine.

**4.2 Sample Cutter** Thwing Albert sample cutter, Model No. JDC-50, or equivalent.

**4.3 Test Fixture** Free wheeling rotary drum (Figure 2), sliding plate (Figure 3), or equivalent. The referee fixture will be a 152.4 mm [6.0 in] free wheeling rotary drum.

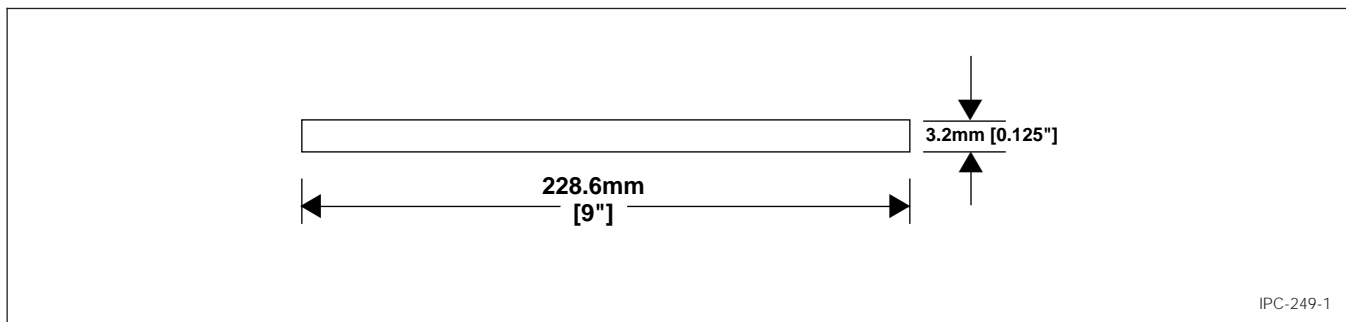

**Figure 1 Type A peel strength test pattern**

IPC-TM-650		
Number <b>2.4.9</b>	Subject <b>Peel Strength, Flexible Printed Wiring Materials</b>	Date <b>10/88</b>
Revision <b>D</b>		

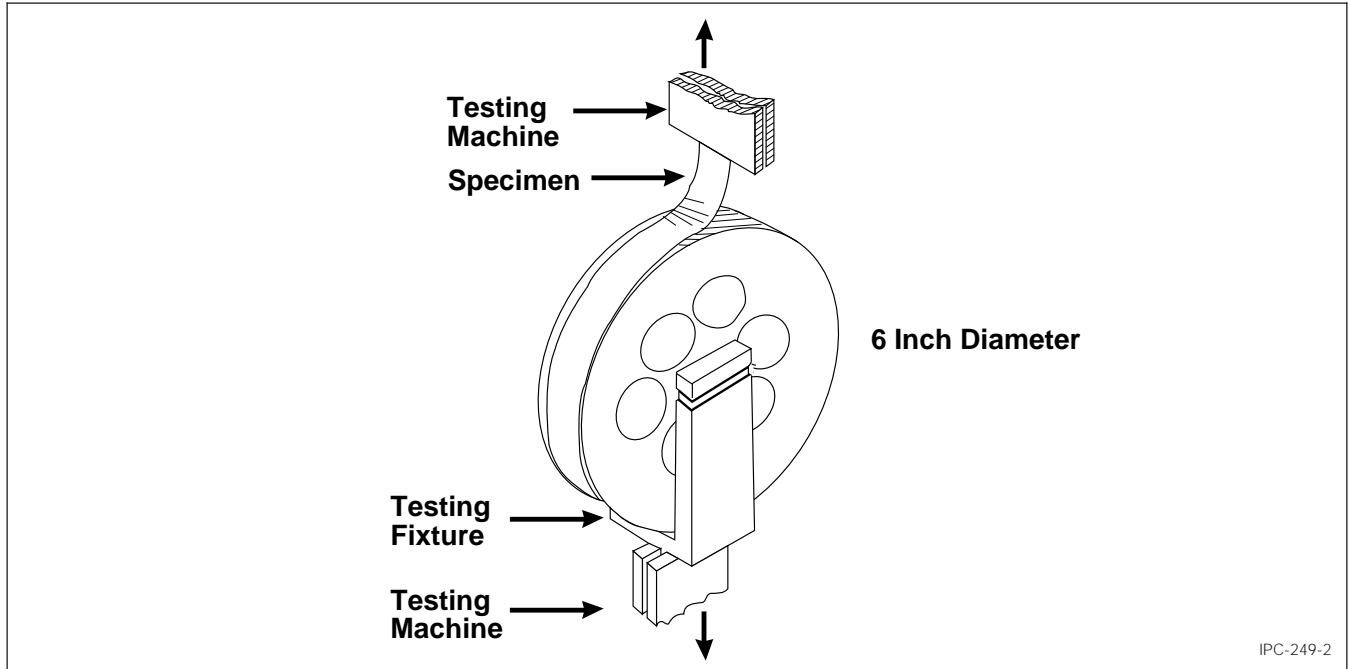

**Figure 2 Free wheeling rotary drum test fixture**

**4.4 Solder Pot** An electrically-heated, thermostatically controlled solder pot of adequate dimensions to accommodate the specimen and contain no less than 2.25 Kg [5 pounds] of SN60 solder.

**4.5 Automatic Temperature Cycling Chamber** (See 5.5.3)

## 5.0 Procedure

### 5.1 Method A—As Received-Etched Specimen

**5.1.1** Prepare Type A etched conductor test specimens in accordance with Figure 1 using standard commercial practices per paragraph 3.1.2.

**5.1.2** Condition specimens for 24 hours at  $23 \pm 2^\circ\text{C}$  ( $73.4 \pm 3.6^\circ\text{F}$ ) and  $50 \pm 5\%$  relative humidity. Stabilization time may be reduced if statistically sound evidence has been generated on the specific product line to support the shorter stabilization times.

**5.1.3** Attach the specimen to the test fixture with double-sided tape, cement, and/or mechanical clamps. The referee attachment technique will be double sided adhesive tape.

**5.1.4** Peel the conductor at a rate (crosshead speed) of 50.8 mm/minute [2 inches/minute]. The peel load shall fall within 15 to 85 percent of the range of the scale used on the testing machine. The peel load shall be continuously recorded, and the recorded load for the entire length of the peeled conductor shall be evaluated per paragraph 5.7.1. A minimum of 57.2 mm [2-1/4 inches] must be peeled, the first 6.4 mm [1/4 inch] to be disregarded.

### 5.2 Method B—As Received—Die Cut Specimen

**5.2.1** Cut Type B test specimens with the Thwing Albert sample cutter per paragraph 3.2.2.

**5.2.2** Condition specimens for 24 hours at  $23 \pm 2^\circ\text{C}$  ( $73.4 \pm 3.6^\circ\text{F}$ ) and  $50 \pm 5\%$  relative humidity. Stabilization times may be reduced if statistically sound evidence has been generated on the specific product line to support the shorter stabilization times.

**5.2.3** Attach the specimen to the test fixture with double-sided tape, cement, and/or mechanical clamps. The referee attachment technique will be double sided adhesive tape.

IPC-TM-650		
Number 2.4.9	Subject Peel Strength, Flexible Printed Wiring Materials	Date 10/88
Revision D		

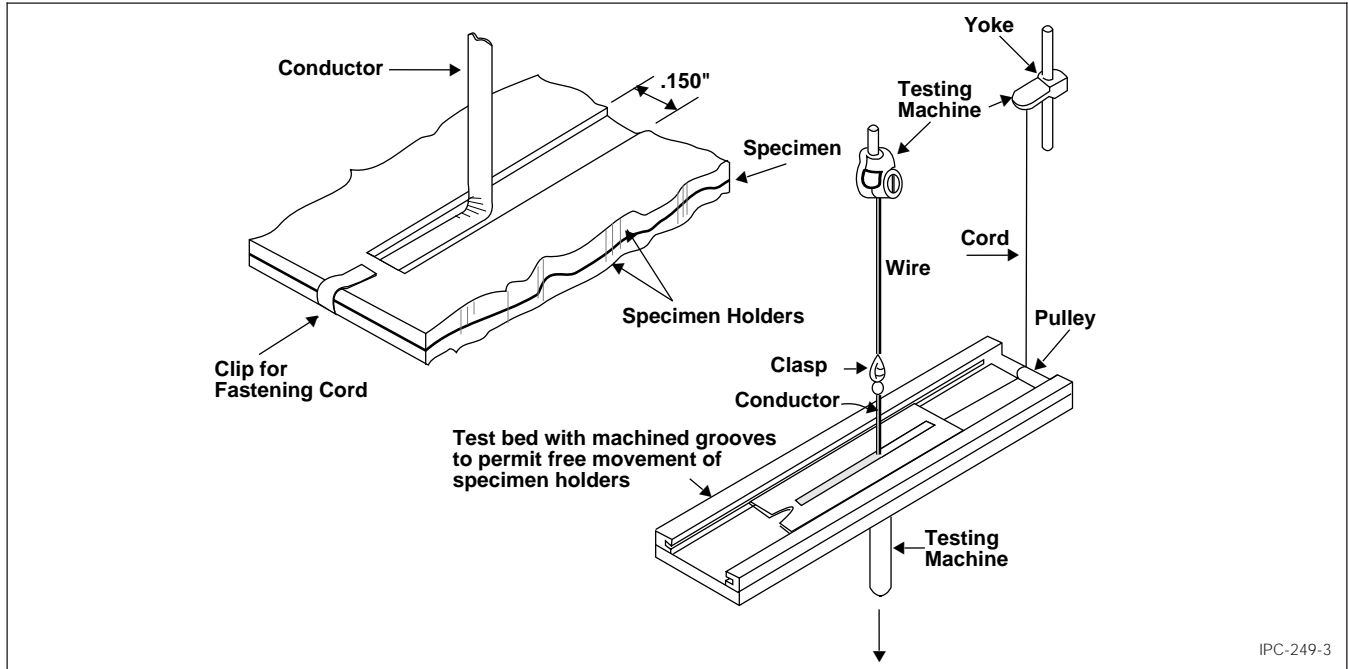

**Figure 3 Sliding plate test fixture**

**5.2.4** Peel the foil at a rate (crosshead speed) of 508 mm/minute [2 inches/minute]. The peel load shall fall within 15 to 85 percent of the range of the scale used on the testing machine. The peel load shall be continuously recorded, and the recorded load for the entire length of the peeled conductor shall be evaluated per paragraph 5.71. A minimum of 57.2 mm [2-1/4 inches] must be peeled, the first 6.4 mm [1/4 inch] to be disregarded.

### 5.3 Method C—Solder Float—Etched Specimen

**5.3.1** Prepare Type A etched conductor test specimen in accordance with Figure 1 using standard commercial practices per paragraph 3.2.1.

**5.3.2** Dry the test specimens in an area circulating oven maintained at  $135 \pm 10^\circ\text{C}$  ( $275 \pm 18^\circ\text{F}$ ) for one hour.

**5.3.3** Remove the specimen from the conditioning chamber and float each specimen, conductor side down, just beneath the surface of molten solder at  $288 \pm 6^\circ\text{C}$  [ $550 \pm 10^\circ\text{F}$ ] for at least 5 seconds. Agitate the specimen from side to side during immersion, then remove the specimen and tap the edge to remove excess solder. Suitable procedures must be used to ensure that solder does not remain on test specimen.

**5.3.4** Repeat steps 5.1.2 through 5.1.4 as performed in Method A.

### 5.4 Method D—Solder Float—Die Cut Specimen

**5.4.1** Cut Type B test specimens with the Thwing Albert sample cutter per paragraph 3.2.1.

**5.4.2** Dry the test specimens in an air circulating oven maintained at  $135 \pm 10^\circ\text{C}$  ( $275 \pm 18^\circ\text{F}$ ) for one hour.

**5.4.3** Remove the specimen from the conditioning chamber, apply solder stop (e.g. petroleum jelly) and float each specimen, conductor side down, just beneath the surface of molten solder at  $288 \pm 6^\circ\text{C}$  [ $550 \pm 10^\circ\text{F}$ ] for at least 5 seconds. Agitate the specimen from side to side during immersion, then remove the specimen and tap the edge to remove excess solder. Suitable procedures must be used to ensure that solder does not remain on test specimen.

**5.4.4** Repeat steps 5.2.2 through Method B.

### 5.5 Method E—After Aging Etched Specimen

IPC-TM-650		
Number <b>2.4.9</b>	Subject <b>Peel Strength, Flexible Printed Wiring Materials</b>	Date <b>10/88</b>
Revision <b>D</b>		

**5.5.1** Prepare Type A etched conductor test specimen in accordance with Figure 1 using standard commercial practices per paragraph 3.1.1.

**5.5.2** Condition specimens for 24 hours at  $23 \pm 2^\circ\text{C}$  ( $73.4 \pm 3.6^\circ\text{F}$ ) and  $50 \pm 5\%$  relative humidity. Stabilization time may be reduced if statistically sound evidence has been generated on the specific product line to support the shorter stabilization times.

**5.5.3** Expose each test specimen to five cycles at the time-temperature sequence: 1/2 hour at  $150^\circ +5^\circ -0^\circ\text{C}$  [ $302^\circ +9^\circ -0^\circ\text{F}$ ], 1/4 hour at  $23^\circ \pm 10^\circ\text{C}$  [ $73.4^\circ \pm 18^\circ\text{F}$ ], 1/2 hour at  $-55^\circ -5^\circ +0^\circ\text{C}$  [ $-67^\circ -9^\circ +0^\circ\text{F}$ ], 1/4 hour at  $23^\circ \pm 10^\circ\text{C}$  [ $73.4^\circ \pm 18^\circ\text{F}$ ].

**5.5.4** Repeat steps 5.1.2 through 5.1.4 as performed in Method A.

## 5.6 Method F—After aging—Die Cut Specimen

**5.6.1** Cut Type B test specimens with the Thwing Albert sample cutter per paragraph 3.2.1.

**5.6.2** Condition specimens for 24 hours at  $23 \pm 2^\circ\text{C}$  ( $73.4 \pm 3.6^\circ\text{F}$ ) and  $50 \pm 5\%$  relative humidity. Stabilization time may be reduced if statistically sound evidence has been generated on the specific product line to support the shorter stabilization times.

**5.6.3** Expose each test specimen to five cycles at the time-temperature sequence: 1/2 hour at  $150^\circ +5^\circ -0^\circ\text{C}$  [ $302^\circ +9^\circ -0^\circ\text{F}$ ], 1/4 hour at  $23^\circ \pm 10^\circ\text{C}$  [ $73.4^\circ \pm 18^\circ\text{F}$ ], 1/2 hour at  $-55^\circ -5^\circ +0^\circ\text{C}$  [ $-67^\circ -9^\circ +0^\circ\text{F}$ ], 1/4 hour at  $23^\circ \pm 10^\circ\text{C}$  [ $73.4^\circ \pm 18^\circ\text{F}$ ].

**5.6.4** Repeat steps 5.2.2 through 5.2.4 as performed in Method B.

## 5.7 Evaluation

**5.7.1** Average the chart recordings for both specimens over the entire peel length if the mode of failure hasn't changed. In the case of changes in failure mode, the average specimen peel strength shall be determined using the area of the chart associated with the failure mode producing the lowest peel strength number (see Figures 4, 5 and 6).

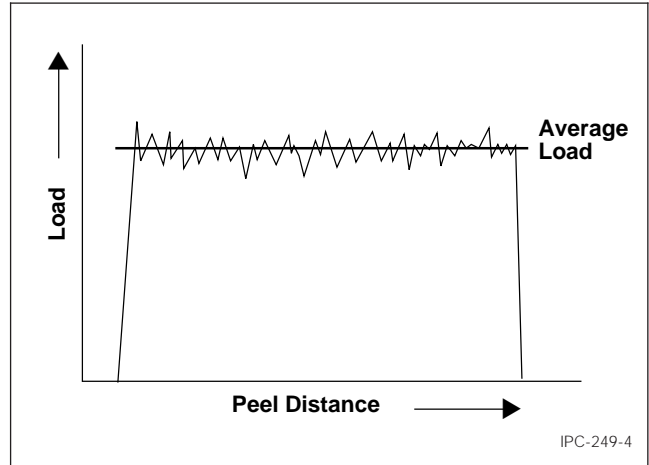

Figure 4 Single failure mode

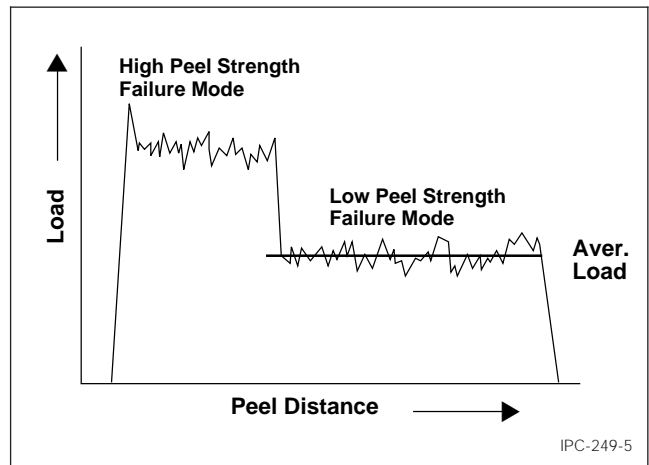

Figure 5 Multiple failure modes

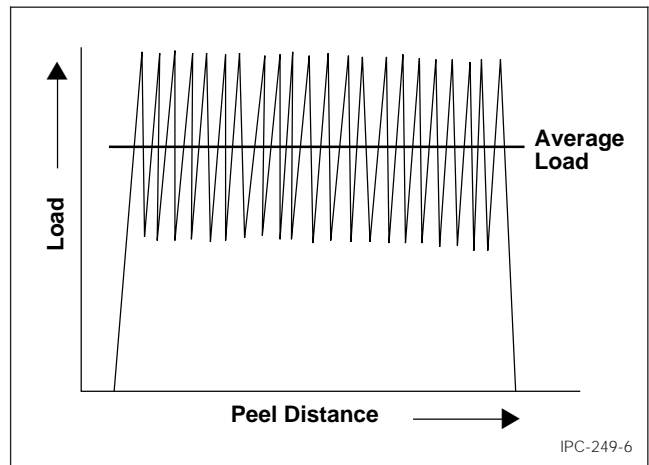

Figure 6 Slip-stick failure mode

IPC-TM-650		
Number <b>2.4.9</b>	Subject <b>Peel Strength, Flexible Printed Wiring Materials</b>	Date <b>10/88</b>
Revision <b>D</b>		

**5.7.2** Measure and record the width of the etched conductor or peeled foil to the nearest 0.02 mm [0.001 inch].

**5.7.3** Compute the peel strength using the following formula: Peel Strength (pounds/inch of width) = Average load per 5.7.1 conductor width per specimen.

## **6.0 Notes**

**6.1** The force required to bend the test conductor will affect the measured peel strength. The magnitude of this effect will increase as the conductor thickness increases.

**6.2** In order to prevent tenting of the peel specimens, suitable support material may be applied to the back side of the test specimen. A referee support material will be a 0.25 mm [10 mil] glass epoxy material. Bonding during sample preparation should occur at conditions not exceeding 65.6°-9° +0°C [150° -10° +0°F] 1 hour cure @ 100 psi. In the event of a conflict, a backer will be used to prevent tenting. **Note:** The copper foil on the nontest side may remain to provide stability to prevent tenting of the specimen from the German Wheel.

**6.3 Definition:** Slipstick failure is a peel failure which propagates faster than the crosshead speed (also known as a zipper failure).