



# IPC-TM-650 TEST METHODS MANUAL

## 1.0 Scope

1.1 To determine the solderability of electrical contacts intended for such termination.

## 2.0 Reference Documents

2.1 Information in this section is intended to parallel the test method described in EIA-RS-178A.

2.2 **QQ-S-571** Solder; Lead Alloy, Tin Alloy, Tin-Lead Alloy; Flux Cored Ribbon and Wire, and Solid Form.

2.3 **LLL-R-626** Rosin, Gum; Rosin, Wood; Rosin, Tall Oil.

## 3.0 Test Specimen

3.1 The contacts of a connector or individual contacts.

**NOTE:** For wire-hole contacts, it is desirable that a short length of solid copper wire of appropriate size be affixed as shown in Figure 1.

3.2 Unless otherwise specified in the individual contact or connector specification, the test samples shall not be cleaned by any means prior to the test. Care shall be exercised to avoid contamination (grease, perspirants, etc.) of the surface to be tested.

## 4.0 Apparatus and Materials

4.1 Solder pot, having a minimum capacity of 2 pounds, electrically heated, and thermostatically controlled to provide and maintain the solder temperatures required.

4.2 A temperature measuring device of suitable range for the specified test condition and an appropriate stainless steel jacketed thermocouple.

4.3 Dipping device similar to that shown in Figure 2.

4.4 Solder (Sn 60) conforming to Federal Specification QQ-S-571.

Number <b>3.10</b>	
Subject <b>Solderability, Connectors</b>	
Date <b>7/75</b>	Revision <b>A</b>
Originating Task Group <b>N/A</b>	

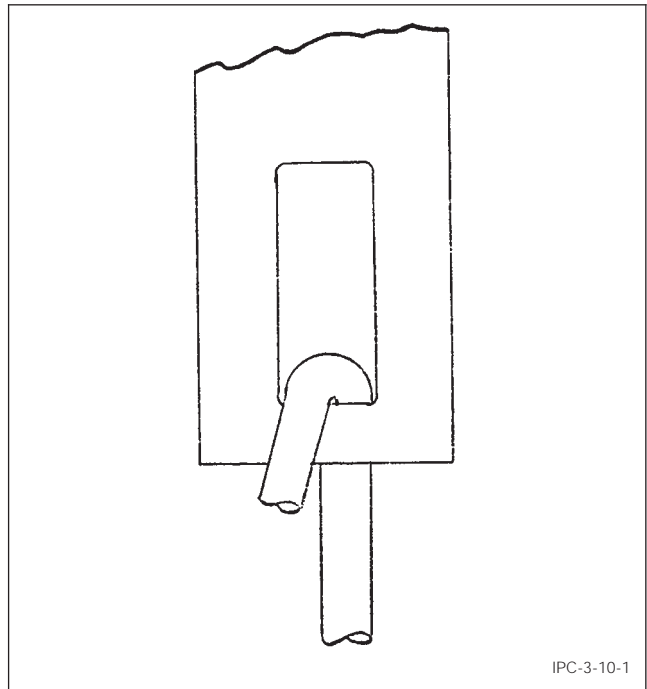

Figure 1 Wire Hole Termination

4.5 Flux of non-corrosive type, composed of 25 percent (by weight) rosin and 75 percent (by weight) alcohol. The rosin shall be Class A, Type 1, Grade WW in accordance with Federal Specification LLL-R-626. The alcohol shall be 99 percent isopropyl alcohol. The flux shall be free of additional activators.

## 5.0 Procedure

5.1 The solder pot temperature shall be adjusted to, and maintained at, the specified test temperature shown in Table 1 for a minimum period of 2 hours prior to test.

Table 1 Test Temperatures

Condition	Temperature
1	232 ± 5°C
2	271 ± 5°C

5.2 The portion of the contact to be soldered shall be immersed in flux for a minimum period of 5 seconds and then allowed to drain for a minimum period of 60 seconds prior to test.

IPC-TM-650		
Number <b>3.10</b>	Subject <b>Solderability, Connectors</b>	Date <b>7/75</b>
Revision <b>A</b>		

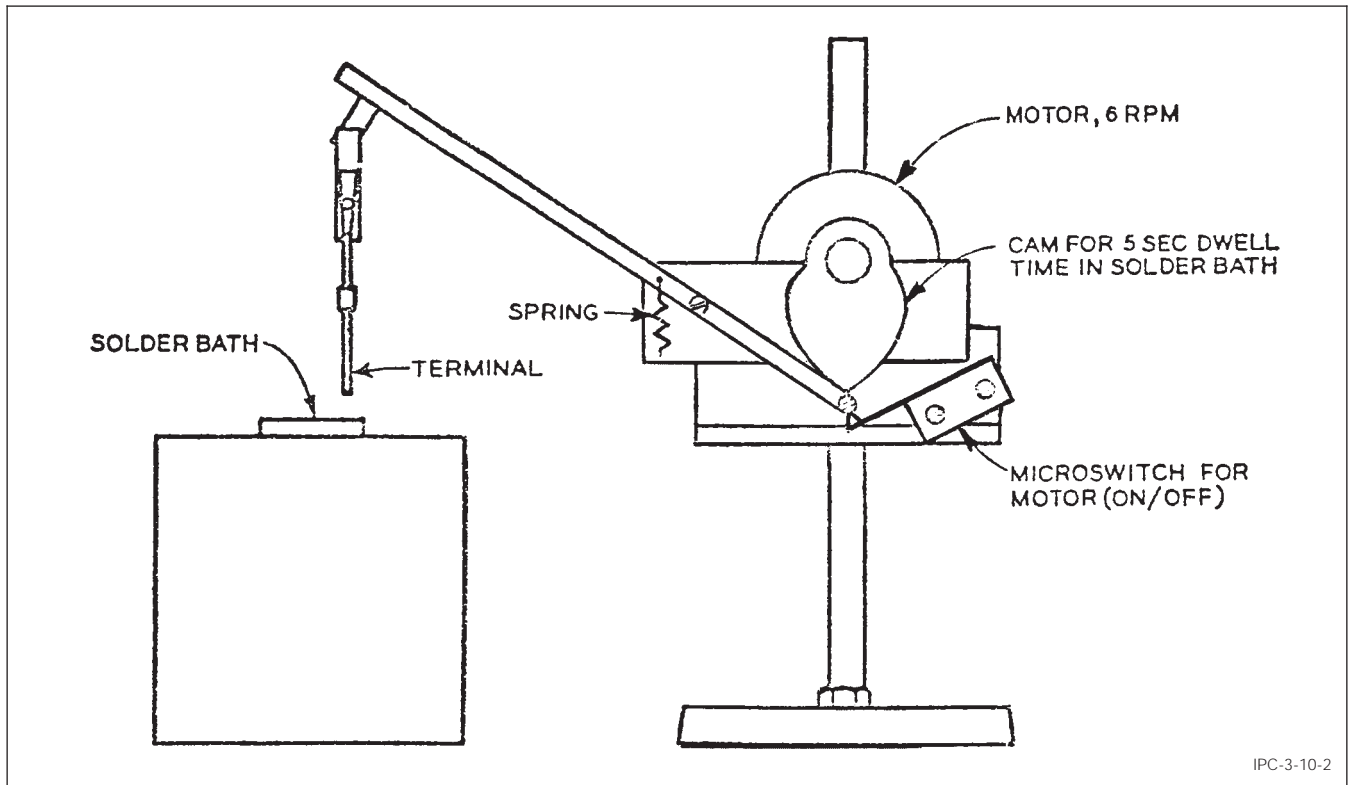

IPC-3-10-2

**Figure 2 Suggested Dipping Device for Solderability Test**

**5.3** The solder bath shall be occasionally stirred with a clean stainless steel paddle to ensure that it is of uniform composition and temperature throughout. The surface of the bath shall be skimmed immediately prior to each test to remove any dross or residual unburned flux from previous tests.

**5.4** The sample shall be affixed to the dipping device shown in Figure 2 and oriented so that the contact termination will enter the solder bath to the specified depth.

**5.5** The sample shall be immersed in the solder bath at a rate of  $1.00 \pm 0.25$  inches per second and withdrawn at the same rate. The dwell time in the solder shall be  $5.0 \pm 0.5$  seconds.

**5.6** The sample shall not be removed from the dipping device or otherwise disturbed until the solder has solidified.

**5.7** The sample shall be thoroughly cleaned of residual flux and examined under 10X magnification for evidence of the following:

- A. Dewetting of areas to be soldered.
- B. Pinholes or voids in the solder coat.
- C. Incomplete fill of solder well or hole.

**6.0 Notes**

**6.1** Acceptance criteria shall be established in terms of one, or any combination, of the following:

- A. Less than 95% coverage of flat surfaces.
- B. Pinholes or small voids or solder surface roughness concentrated in any one area of the contact.
- C. Poor filleting around wire or incomplete fill of solder well.